

Improvement of Power Quality using Unified Power Quality Conditioner with Distributed Generation

Prof. S. S. Khalse

Faculty, Electrical Engineering Department, Csmss Chh Shahu College of Engineering, Aurangabad, India.

Abstract - Recently power quality has become more important issue. Now a day's power electronics based appliances are widely used in industries and in distribution system which creates more power quality problems. The power electronics based power conditioning devices can be an effective solution to improve power quality in power system. Unified Power Quality Conditioner (UPQC) is one of the custom power devices which are used to solve voltage and current related problems simultaneously. In this paper, combined operation of UPQC with Distributed Generation (DG) is discussed. This system integrated with wind energy is able to compensate voltage sag/swell, load current disturbances. Also proposed system is able to compensate voltage interruption and active power transfer to load and source in both interconnected and islanding mode and help to improve power quality. The operation of UPQC with DG has been evaluated through simulation studies using MATLAB/SIMULINK software.

Index Terms— *Uninterruptible Power Supplies (UPS), Unified Power Quality Conditioner (UPQC), Distributed Generation (DG), Point of Common Coupling (PCC), Voltage Source Inverter (VSI), Distribution Static Compensator (DSTATCOM), Dynamic Voltage Restorer (DVR), Fast Fourier Transform (FFT).*

I. INTRODUCTION

In electrical power system power electronics devices plays an important role. In distribution system it has three aspect first one is that introduces valuable industrial and domestic equipments, second one is that creates problems, third one is that help to solve problems. Now a day's modern semiconductor switching devices such as controlled rectifiers, Uninterruptible Power Supplies (UPS), arc furnaces etc. are widely used particularly in domestic and industrial loads.

These non linear loads create power quality problems such as voltage sag, voltage swell, voltage interruption, voltage flickers, voltage spikes, harmonics etc. Such poor power quality causes increase in power losses and other remarkable abnormalities in distribution sides. Thus, it is very important to maintain a high standard of power quality. Earlier passive filters were used to solve power quality problems. However because of some limitations of passive filters, now a day's custom power devices are used to solve power quality problems in distribution side.

The compensating custom power devices are used for active filtering, load balancing, power factor improvement and voltage regulating (sag/swell). There are three types of custom power devices: Distribution Static Compensator (DSTAT-COM), Dynamic Voltage Restorer (DVR) and Unified Power Quality Conditioner (UPQC).

Unified Power Quality Conditioner (UPQC) is one of the custom power devices, which can solve voltage and current related problem simultaneously. This is connected before load to make load voltage distortion free and at the same

time reactive current drawn from source should be compensated in such a way that the currents at source side would be in phase with supply voltage.

The interest in Distributed Generation (DG) has been increased rapidly. The world wide concern about environmental pollution and the energy shortage has led to the increasing interest in generation of renewable electrical energy. As Distributed Generation (DG) play very important role in power system and help to solve many problems that ac conventional power system has. There are several DGs such as PV system, fuel cell, wind turbine. Wind power has become fastest growing energy source among various renewable energy source. In this paper deals with combined operation of UPQC with wind energy and output of DG system is connected to DC bus of UPQC. The UPQC with DG help to compensate Voltage and current power quality problems and have give additional benefit by providing the power to load whenever voltage interruption occur with source side [1].

This paper discussed combined operation of UPQC with DG and this system is integrated with wind energy. The proposed system is able to compensate voltage sag/swell, load current disturbances. In addition to this it is able to compensate voltage interruption and active power transfer to load and source in both interconnected and islanding mode and help to improve power quality. The operation of UPQC with DG has been evaluated through simulation studies using MATLAB/SIMULINK software [2].

II. SYSTEM DESCRIPTIONS

UPQC has two voltage-source inverters which are connected back to back by common DC bus. A series inverter is connect-ed through transformer between source and PCC and a shunt inverter is connected across load. Series inverter is responsible for mitigation of supply side disturbances such as voltage sag/swell, flickers, voltage unbalance. It inserts voltage so as to maintain the load voltage at desire level, balanced and distortion free. The shunt inverter is responsible for mitigating the current related problems caused by consumers such as poor power factor, load harmonic currents, load unbalance etc. It injects current in system in such a way that source current become balanced, sinusoids and in phase with the supply voltage. The general block diagram of UPQC is shown in figure 1

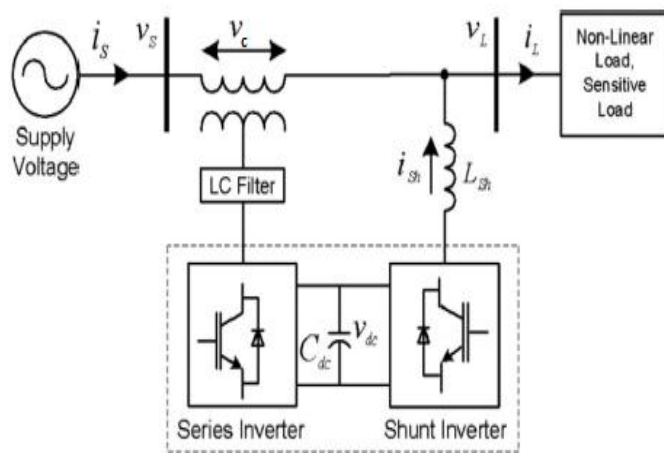

Fig1. General block diagram of UPQC

In this paper, the system under consideration is as shown in figure 2. It consists of three phase four wire UPQC with wind energy source as DG and its output is connected to DC bus of UPQC. The system neutral is connected to the negative terminal of DC link voltage to avoid the requirement of fourth leg in Voltage Source Inverter (VSI) of shunt active filter [3],[4]. This system has two modes of operation - interconnected mode in which DG provide power to source and load and islanding mode in which DG provide power to load within its power rating.

The proposed system also consists of two DC storage device but each leg of VSI can be controlled independently V_{as}, V_{bs}, V_{cs} are three phase source voltages V_{ta}, V_{tb}, V_{tc} are the terminal voltages and voltages injected by series active filters $V_{inja}, V_{inj b}, V_{inj c}$ and of phase a, b and c respectively. The three phase source currents are i_{sa}, i_{sb}, i_{sc} . The load currents are i_{la}, i_{lb}, i_{lc} and current injected by shunt active filter are i_{fa}, i_{fb}, i_{fc} . The feeder resistance and inductance are R_s and L_s and respectively. The interfacing inductance and resistance of shunt active filter are L_f and R_f respectively. The interfacing inductance and capacitance of series active filter L_{se} are C_{se} and respectively. The total DC link voltage is $V_{dcbus} (V_{dc1} + V_{dc2}) = 2V_{dc}$ and I_n is the neutral current

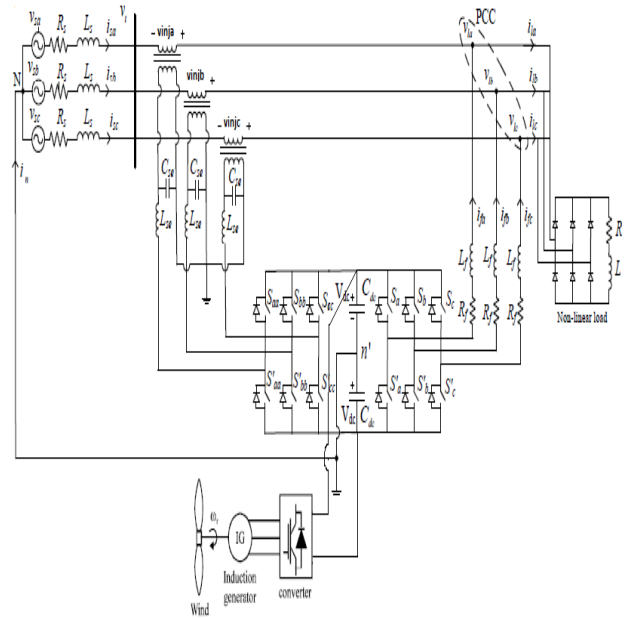

Fig 2. Proposed system

III. WIND ENERGY GENERATING SYSTEM

In this system, the wind generation is based on constant speed topology with pitch control turbine and induction generator is used in this system because of its simplicity as it does not re-quire a separate field circuit and diode bridge rectifier is used to convert power generated by induction generator into dc power. The output power of the turbine is given by the follow-ing equation [8].

$$P_m = C_p(\lambda, \beta) \frac{\rho A}{2} (V_{wind})^3$$

where,

- P_m Mechanical output power of the turbine (W)
- C_p Performance coefficient of the turbine
- ρ Air density (kg/m^3)
- A Turbine swept area (m^2)
- V_{wind} Wind speed (m/s)
- λ Tip speed ratio of the rotor blade tip speed to wind speed
- β Blade pitch angle (deg)

IV. MATLAB/SIMULINK MODEL

The power circuit is modeled as a three phase four wire system with a nonlinear load that is composed of a three phase diode bridge rectifier with RL load as shown in figure 4.

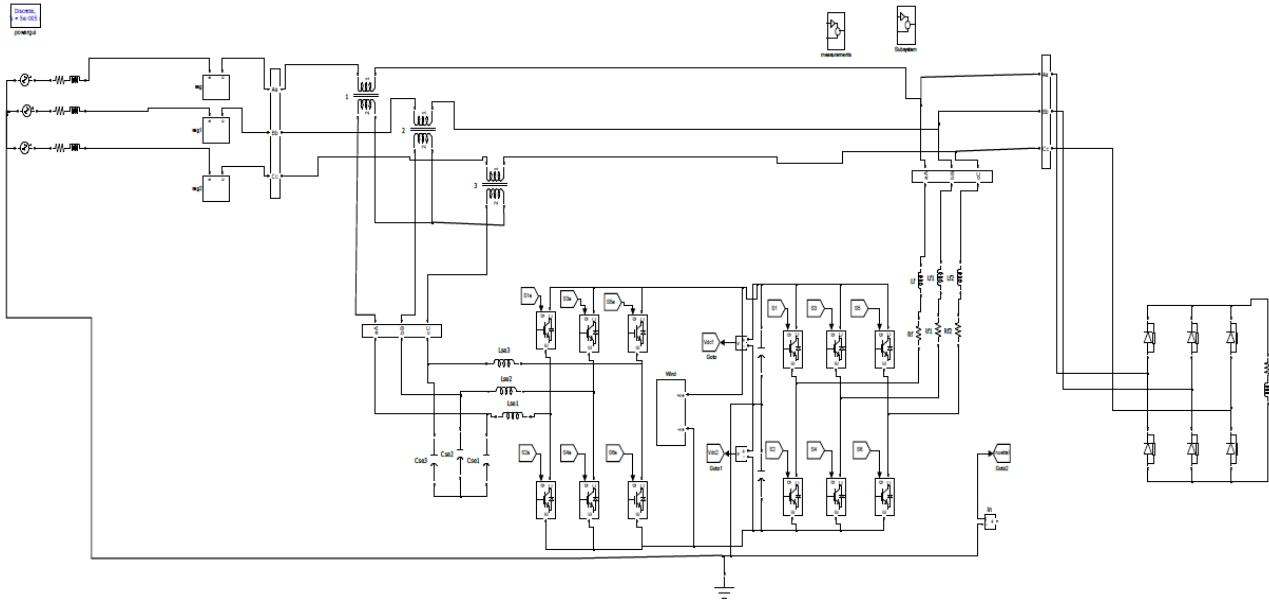

Fig 4. MATLAB/SIMULINK model of system

V. SIMULATION RESULTS

In this paper, three phase four wire 230V (line-neutral) 50Hz system is considered. There are two operation modes in the proposed system. One is called the interconnected mode, in which the DG provides power to the source and the load. The other is called the islanding mode, in which the DG provides power to the load only within its power rating. The operation of proposed system was verified through MATLAB/SIMULINK software.

Fig.5 shows the waveforms of source current, shunt inverter current and load current respectively. When a non-linear load injects harmonic current then it can be compensated using shunt inverter current of UPQC to make source current sinusoidal.

Fig.6 shows the Fast Fourier Transform (FFT) analysis of load current and source current. As shown in FFT analysis, the Total Harmonic Distortion (THD) of supply current is 0.69% and that of load current is 28%.

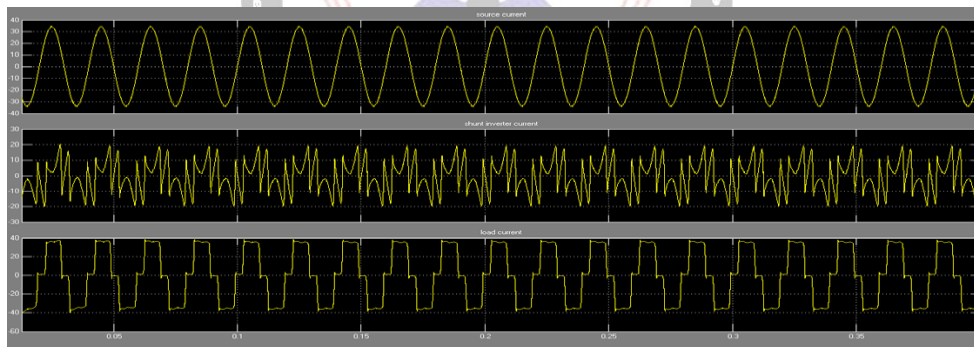

Fig5. Current harmonic compensation (a) Source current (b) Shunt inverter current (c) Load current

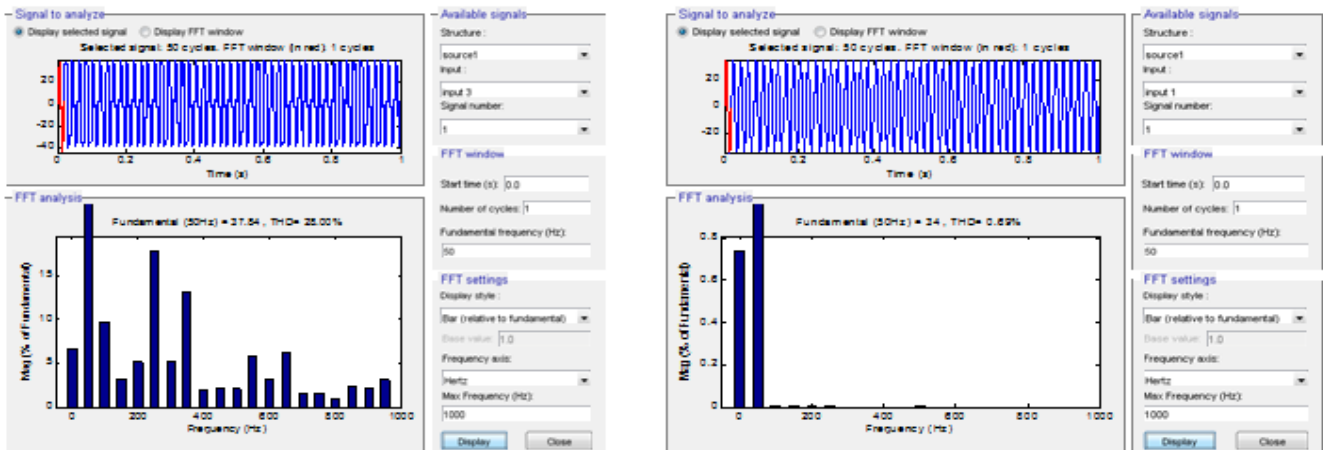

Fig6. Fast Fourier Transform (FFT) analysis of (a) Load current (b) Source current

Fig. 7 represents waveforms of source voltage, series inverter voltage and load voltage. When unbalanced voltage sag (phase A has 10% of swell and phase B and C has 30% of sag) occurs in system from 0.2s to 0.6s then series inverter inject voltage to maintain load voltage at constant level.

Fig. 8 shows active power variation of load, shunt inverter, source and series inverter. During sag interval (from 0.2s to 0.6s) active power of source is reduced from 10 kW to 8kW then series inverter provides 2kW active power to cover this voltage sag.

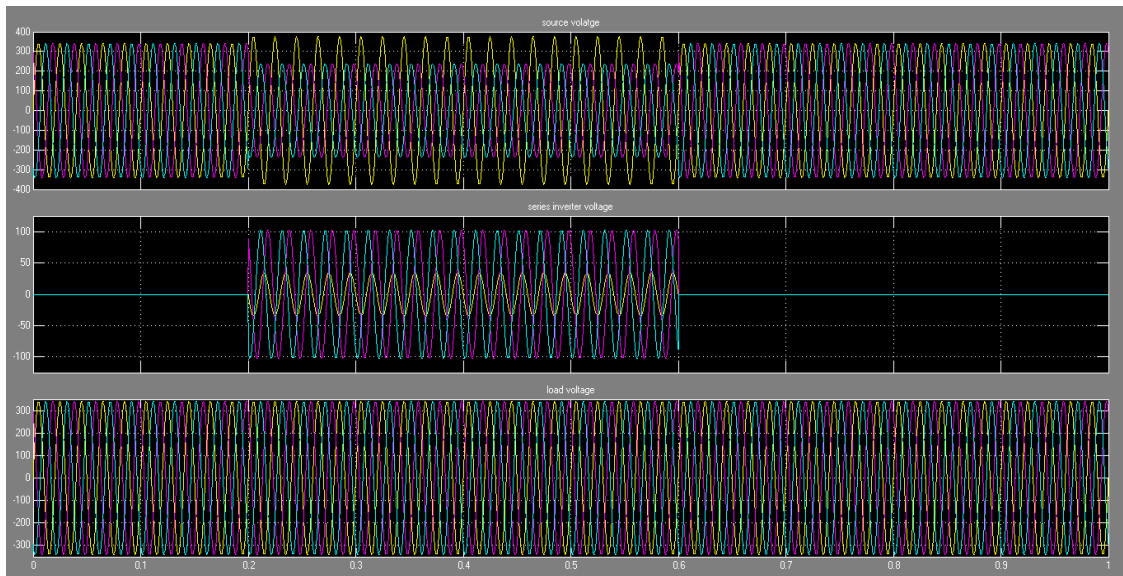

fig7. Voltage sag compensation (unbalanced voltage sag) (a) Source voltage (b) Series inverter voltage (c) Load voltage

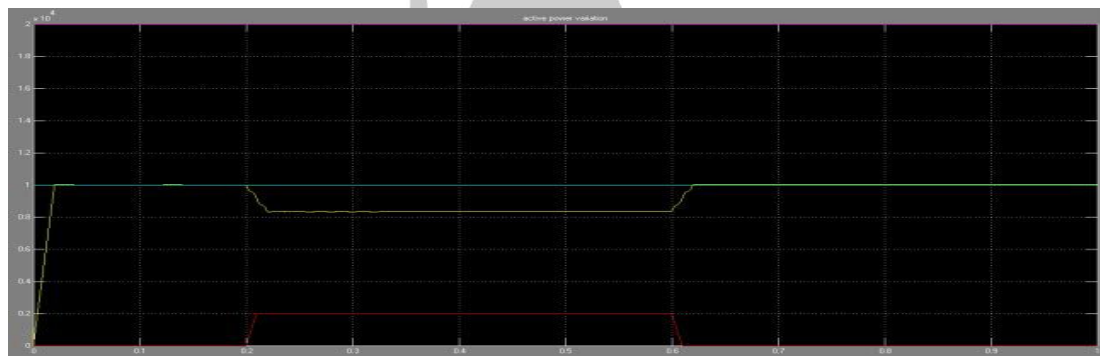

fig8. Active power of (a) Load (b) Shunt inverter (c) Source (d) Series inverter

Fig.9 shows waveforms of source voltage, shunt inverter voltage and load voltage. When voltage interruption occurs from 0.2s to 0.6s then during that interval shunt inverter inject voltage to maintain load voltage constant.

Fig.10 shows the active power of load, shunt inverter, source and series inverter. In forward flow mode, shunt inverter with DG supplies power to the load in parallel with the main source. During normal operation, source and shunt inverter provides 10kW power to load respectively. But when voltage interruption occurs (from 0.2s to 0.6s) active power of source becomes zero and during this interval only shunt inverter provides 20kW active power to load.

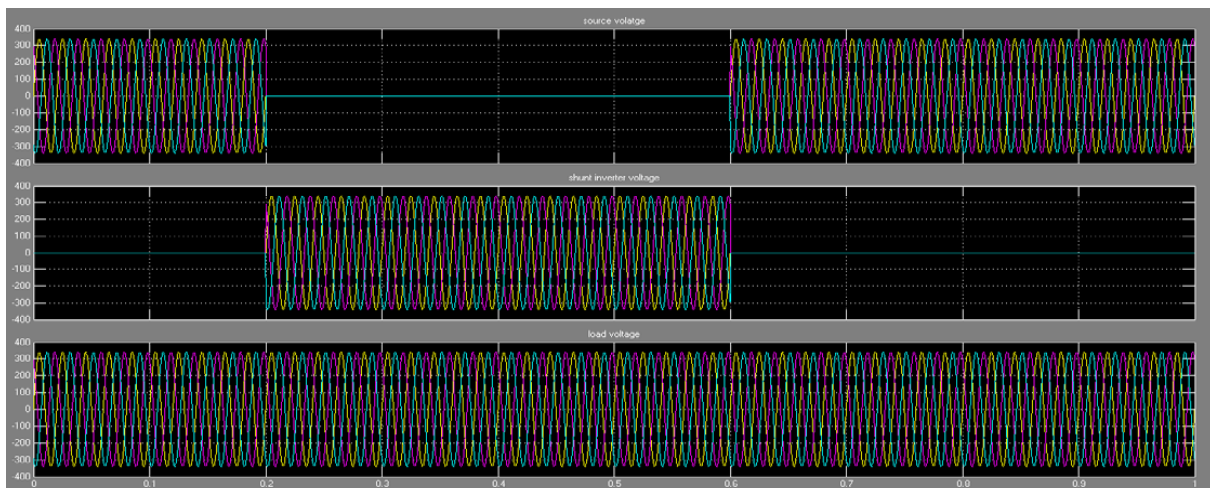

fig9. Voltage interruption (forward flow mode) (a) Source voltage (b) shunt inverter voltage (c) load voltage

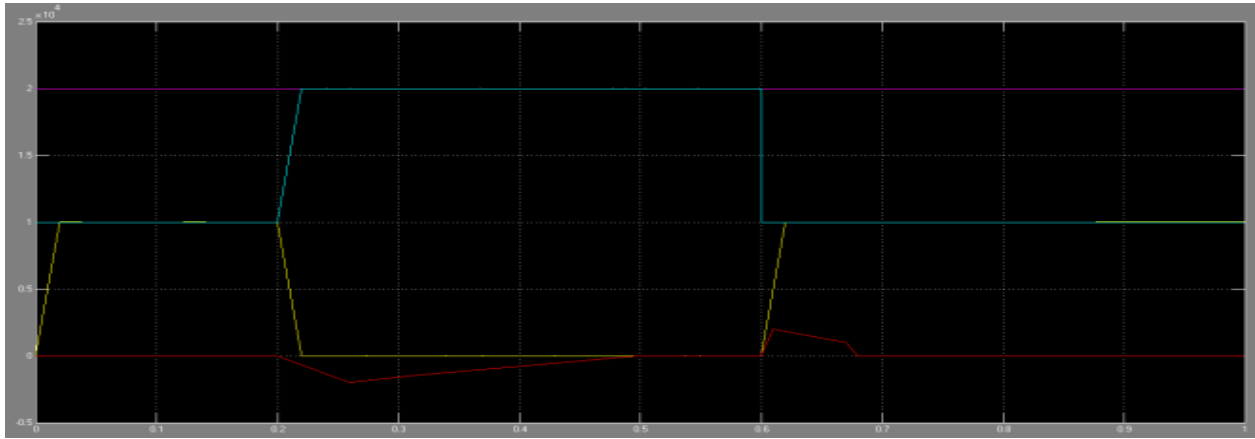

Fig10. Active power of (a) load (b) shunt inverter (c) source (d) series inverter

Fig.11 represents source voltage, series inverter voltage, load voltage waveforms. The balanced voltage sag occur (all phases has 30% of sag) from 0.2s to 0.6s. During this time interval series inverter inject voltage to cover this voltage sag and to maintain load voltage constant.

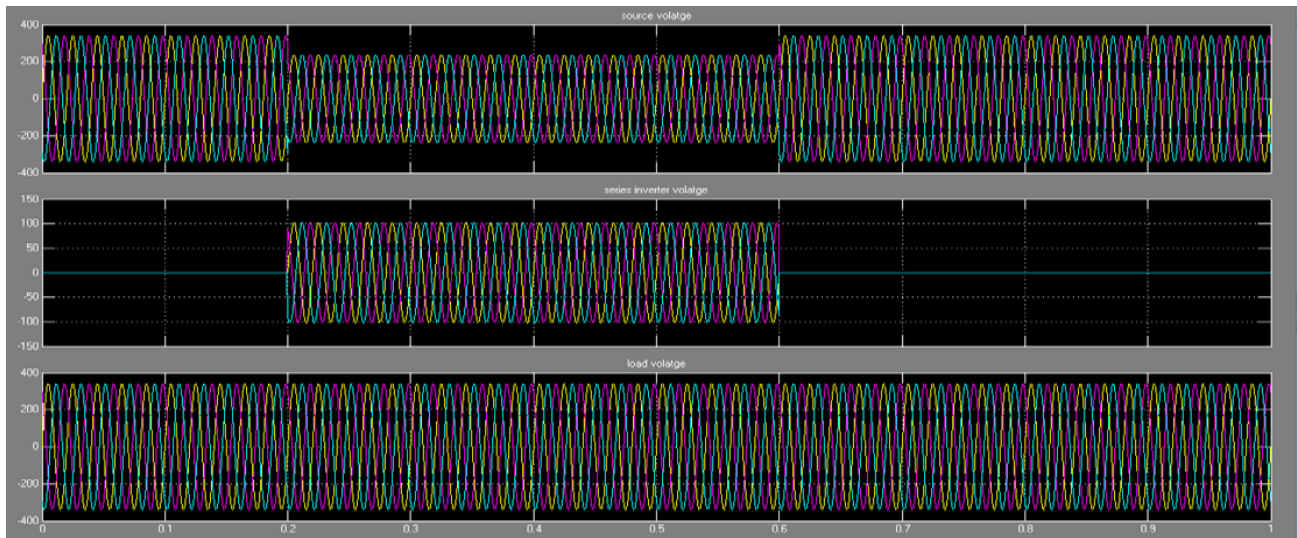

Fig11. Balanced voltage sag compensation. (a) Source voltage (b) Series inverter voltage (c) Load voltage

Fig. 12 shows source voltage, shunt inverter voltage, and load voltage waveforms. When voltage interruption occurs from 0.2s to 0.6s then during that interval shunt inverter inject voltage to maintain load voltage constant. Fig.13 shows active power variation of shunt inverter, load, series inverter and source, respectively.

In reverse-flow mode, the shunt inverter with DG supplies power to the load and the main source. In normal operation, the shunt inverter provides 10-kW power to the load and the source, respectively. But during the voltage interruption, only the shunt inverter provides 10-kW power to the load.

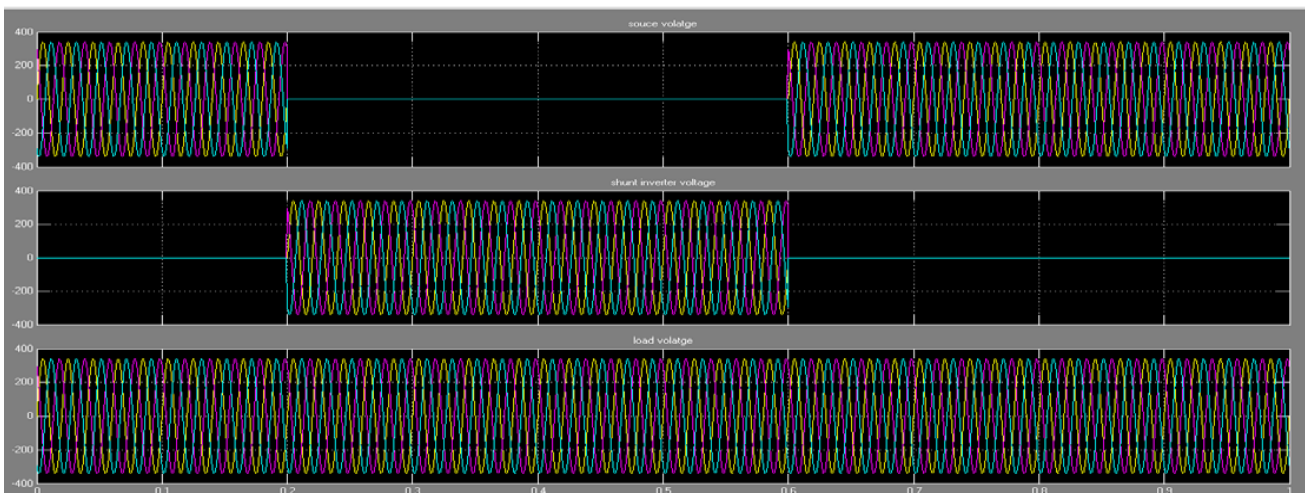

fig12. Voltage interruption (reverse flow mode) (a) Source voltage (b) Shunt inverter voltage (c) Load voltage

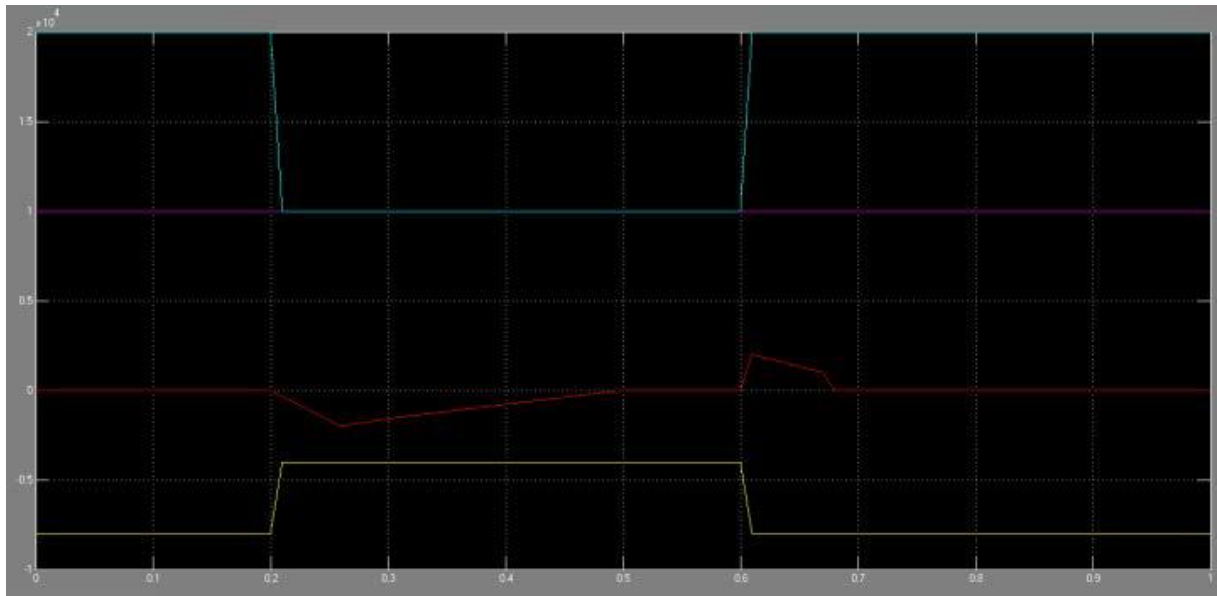

Fig13. Variation of active power of (a) Shunt inverter (b) Load (c) Series inverter (d) Source

VI. CONCLUSION

In this paper, the combined operation of UPQC with DG is explained. The proposed system is composed of series and shunt inverter, wind energy system connected to the DC link through rectifier. The proposed system is able to compensate voltage sag, voltage swell, voltage interruption and current harmonics in interconnected and islanding mode.

Hence, the proposed system improves power quality at the point of installation on power distribution system or industrial power systems. The operation of UPQC with DG has been evaluated through simulation studies using MATLAB/SIMULINK software.

REFERENCES

- [1] Vinod Khadkikar, Member, IEEE, "Enhancing Electric Power Quality Using UPQC: A Comprehensive Overview", IEEE Transactions On Power Electronics, Vol. 27, No. 5, May 2012.
- [2] B. Han, Senior Member, IEEE, B. Bae, H. Kim, And S. Baek, "Combined Operation Of Unified Power-Quality Conditioner With Distributed Generation", IEEE Transactions On Power Delivery, Vol. 21, No. 1, January 2006.
- [3] Srinivas Bhaskar Karanki, Nagesh Geddada, Student Member, IEEE, Mahesh K. Mishra, Senior Member, IEEE, B. Kalyan Kumar, Member, IEEE, "A Modified Three-Phase Four Wire UPQC Topology with Reduced DC-Link Voltage Rating" 2011 IEEE.
- [4] P. Divya Swathi, K. Vijay Kumar, "A New Reduced Type Three Phase Four Wire UPQC Topology for PQ features using VPI" IJIFR volume 2 issue 5 January 2015.
- [5] Kuldeep Kumar Singh, J. K Dwivedi, "Performance Study of Unified Power Quality Conditioner Using Matlab Simulink", International Journal Of Scientific & Technology Research Volume 1, Issue 11, December 2012.
- [6] S. Srikanthan and Mahesh Kumar Mishra, Senior Member, IEEE, "DC Capacitor Voltage Equalization in Neutral Clamped Inverters for DSTAT-COM Application", IEEE Transactions On Industrial Electronics, Vol. 57, No. 8, August 2010.
- [7] M. Aziz, Vinod Kumar, Aasha Chauhan, Bharti Thakur, "Power Quality Improvement by Suppression of Current Harmonics Using Hysteresis Controller Technique", International Journal of Recent Technology and Engineering volume-2, Issue-2, May 2013.
- [8] Sharad W. Mohod, Member, IEEE, and Mohan V. Aware, "A STAT-COM-Control Scheme for Grid Connected Wind Energy System for Power Quality Improvement", IEEE Systems Journal, Vol. 4, No. 3, September 2010.