

Experimental investigation of Heat Transfer for Protruded Rectangular Fin Using Forced Convection

¹Shashi Bhushan Kumar, ²Dr.Pankaj Kumar

¹PG Scholar, ²Assistant Professor, Department of ME, BIT Sindri, Dhanbad, India.

¹shashi10m54.mit@gmail.com, ²deoghar100@gmail.com

Abstract- The paper considers the optimum design of Protruded Rectangular fin using forced convection to achieve maximum Heat dissipation rate, Effectiveness and Efficiency. The optimization problem is solved to determine the value of heat transfer using Fourier's law of Heat Conduction and Newton's law of cooling. As we know that the conductivity of fin material should be maximum and light weight so I selected aluminum alloy with approximate composition of Al-94%, Cu-3%, Mg-1.5%, Mn-0.4% and other some impurities for experimental work. Due to this provision the saving in material, better strength and less weight design protruded rectangular has chosen.

Keywords- Protruded rectangular fin, Heat transfer rate, Effectiveness, Aluminum alloy, light weight.

I. INTRODUCTION

The fin is an extruded surface which is attached to the hot body to increase heat transfer rate to the environment. The value of heat transfer from a body may be determined by conduction, convection or radiation from the body. As we know that the heat transfer can be enhanced by increasing the temperature difference between the base of hot source and environment, by increasing the surface area, heat transfer coefficient of the body and by using forced convection. Generally, fins are used where heat transfer is low, in recent era heat transfer plays important role for any industry; Fins are mostly used to increase the rate of heat transfer from a hot surface. Generally, these are used in thermal engineering applications where cooling is required to protect the damage of equipment. Besides the conventional applications, like as internal combustion engines, compressors and heat exchangers, fins also prove that effective in heat-rejection systems in space vehicles and in the cooling of electronic equipment. Generally, fins are used in the electronics industry to avoid effects of burning or overheating like computer or laptop used everything can be placed in small space. Extruded surfaces (fins) are mostly used in major engineering applications such as refrigeration, air conditioning, automobile and chemical developing equipment. Objective of using extruded surface is to increases heat transfer between the hot surface where fin is attached and its convective, radiative or convective radiative environment.

The optimization process is generally based on two approaches: one is to minimize the volume or mass for a given amount of heat dissipation and the other is to maximize the heat transfer rate for already given volume or mass of fin. The rectangular geometry is widely used because it is easy and inexpensive to manufacture. But on

other hand protruded rectangular fins are more effective and efficient than uniform rectangular fin. It takes less volume (fin material) and space compare to uniform rectangular fin. The triangular and trapezoidal profiles offer lighter fins, but this advantage is often offset by the higher manufacturing costs and safety issue due to their sharp tips. In parabolic fins the heat transfer rate per unit volume slightly greater than protruded rectangular fin. But it uses scarcely be justified because it requires a very high skill operator and its high manufacturing cost. Their uses are consequently restricted to application where the cost of the fins must absolutely be kept at a minimum. [Kobus et al 2006]. It can be observed that a parabolic fin requires a lower volume of fin material to achieve the same heat transfer rate. The concave parabolic profile has been shown to be the ideal choice because it uses the least quality of fin materials for a specified heat transfer duty, but its curved surface makes it more difficult and expensive to manufacture.

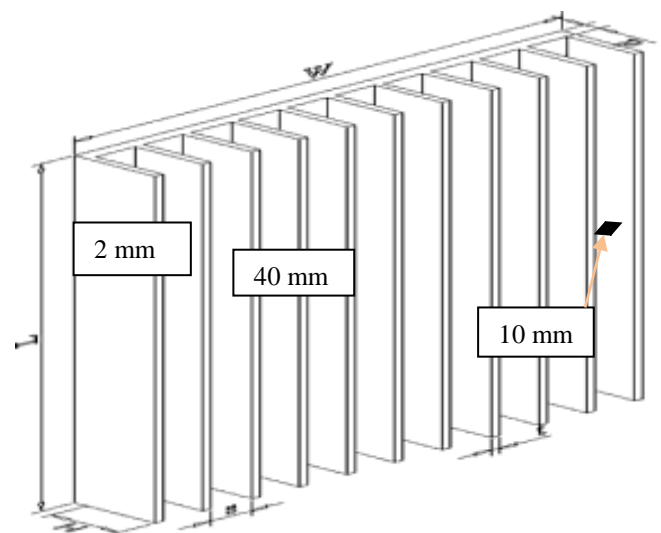

Figure01: Protruded rectangular fin

Step cutting processes: Step cutting process has been done on CNC machine by the removal of material from the work piece to reduce its thickness. To operate the CNC machine, some computer commands have been given, such as G code and M code. G code and M code helps to give the depth of cut, feed rate and spindle speed. To achieve stepped cutting process along the length of work piece, 2 mm depth of cut has been provided after 40 mm tool run. This process has been carried out on top and bottom of the fin to achieve the required size of the fin.

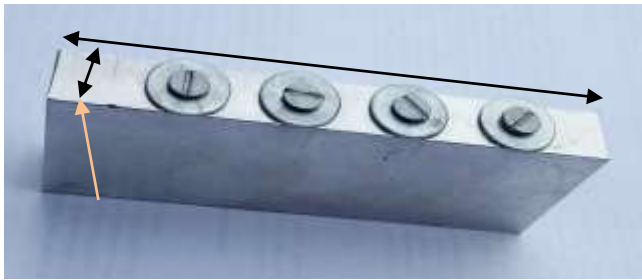

Figure02: Designing of uniform rectangular fin with tapping

II. FABRICATION OF EXPERIMENTAL SETUP

Experimental set-up has been prepared for measurement of required data of fins. Setup is prepared in Heat Transfer Lab, Department of Mechanical Engineering, BIT SINDRI Dhanbad

The experimental setup is used to determine temperature at different point on fin. There is three point of 40 mm distance where temperature indicators are attached to measure temperature. In our experimental setup a duct of 225X125 mm² with fan is required for forced convection analysis. Four heating elements of 65 watt each are required to heat the base temperature of fins which is control by Dimmer stat at different power supply such as 60V, 70V, 80V, 90V, 100V.

After reaching steady state of temperature note the temperature of Temperature Indicator at all points. These temperature readings are help in calculation of finding the values of Heat transfer rate, Effectiveness and Efficiency.



Figure 03: Experimental setup of fins in natural and forced convection analysis.

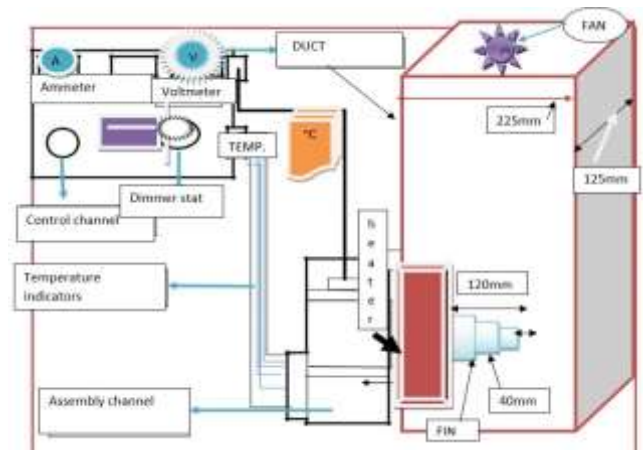

Figure 04:Block diagram of experimental setup

III. DETAILS OF THE EXPERIMENTAL SETUP WITH EQUIPMENT USES.

A) Dimmer stat: - It is a manual operating device. Which is used for giving variable heat input on heater.

B) Voltmeter: - A voltmeter is an instrument used for measuring electrical potential difference between two points in an electric circuit. Which is based on seeback effect in which a temperature difference between two dissimilar electrical conductors or semiconductor produces a voltage difference between the two substances. Analog voltmeters move a pointer across a scale in proportion to the voltage of the circuit. digital voltmeters give a numerical display of voltage by use of an analog to digital converter.

C) Ammeter: - It is a measuring instrument which is used to measure electric current in a circuit. Electric currents are measured in amperes (A) hence the name of instrument is ammeter. which Instruments are used to measure smaller currents in the milliampere or microampere range are designated as milliammeters or microammeters.

D) Heating Element: - It is an element which is used to increase the temperature of base metal (base temperature of fin). There are four heating elements required in our experimental work of 65 watt and volts of 220v-230v each. So, 4*65=260 watt is the power required in project. It is connected with dimmer stat to regulate power supply. And also connected with voltmeter and ammeter to take reading of voltage and current respectively.



Figure 05: Heating element

Temperature indicator (TI):- It is temperature measuring device which is based on working principle of thermocouple. Digital temperature indicator gives a numerical display of temperature due to voltage difference of two dissimilar conductive materials. There are five temperature indicators are required in our project work at different sections. And one is required for environment temperature.



Figure 06: Figure of temperature indicator

- E) **Duct with fan:** - A duct of 225mm X 125mm with 0.3 hp (horse power) is required for forced convection analysis in our project work. The velocity of air in duct is measured by hot wire anemometer.
- F) **Anemometer:** - It is an instrument which is used to measuring velocity of air in duct. For determining Reynolds number to get the value of heat transfer coefficient (h).



Figure 07: Hot wire anemometer

Table 01: Specification of fin

Material	Aluminum Alloy
Length	100 mm
Width	40 mm
Thickness	4 mm
Thermal conductivity	206 w/mK
Density	2.70 g/cm ²
Melting Point	660 °C
Billet size	120X60X8 mm ³

IV. RESULTS AND DISCUSSION

In order to describe the experimental outcomes, graphs are plotted between different parameters obtained from number of observations.

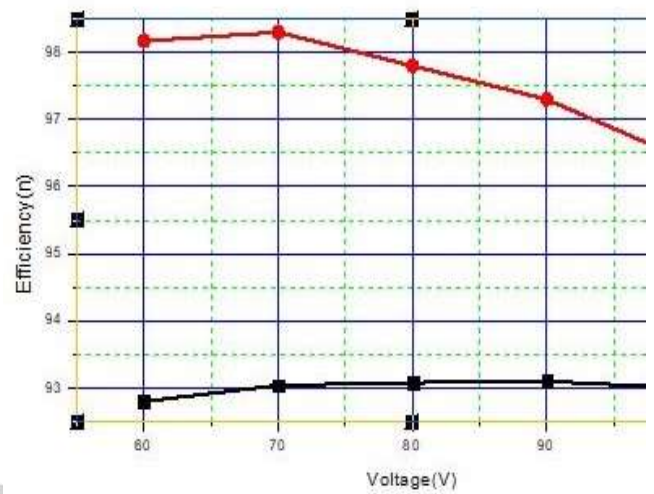

Figure 08: Graph of voltage Vs Efficiency in natural convection

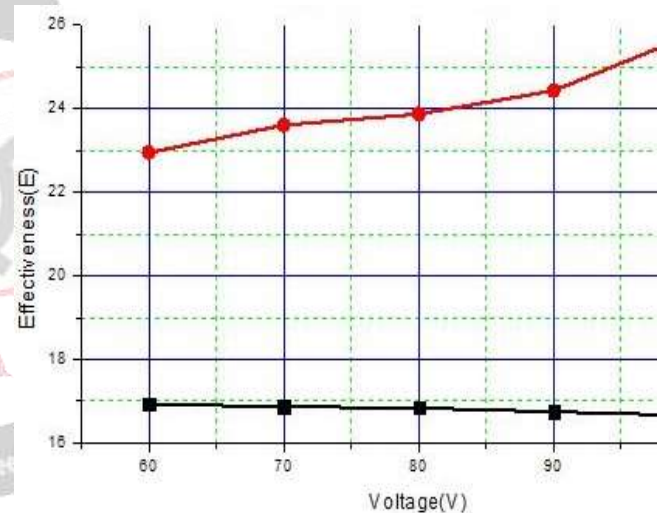

Figure 09: Graph of Voltage Vs Effectiveness in Forced Convection

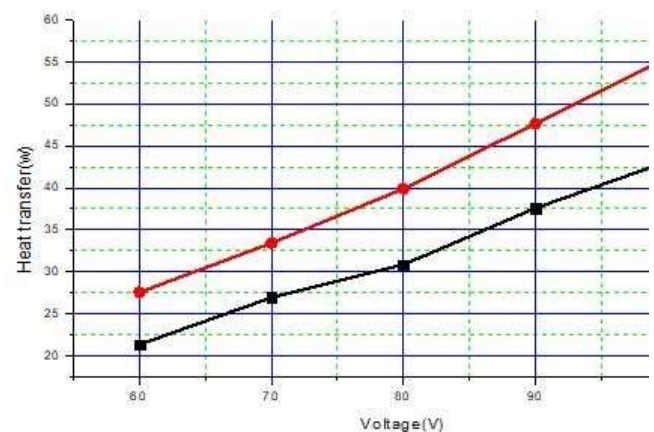

Figure 10: Graph of Voltage Vs Heat transfer rate in natural convection

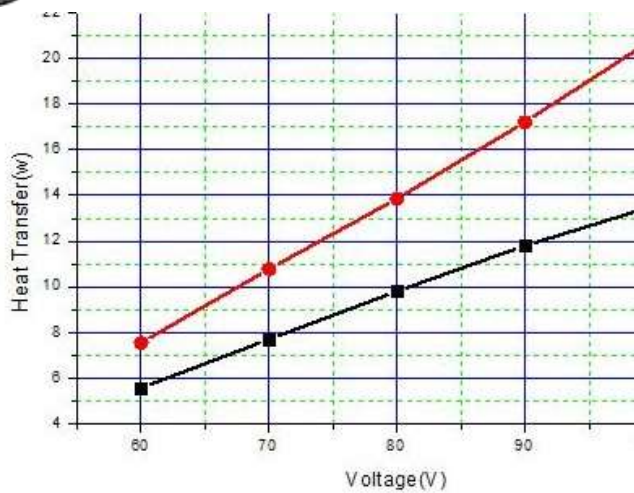

Figure 11: Graph of Voltage Vs Heat transfer rate in forced convection

- ❖ Figure 09 shows the variation of Effectiveness of both fins protruded rectangular fin and Uniform rectangular fin with change in Power supply (Voltage) in forced convection. I observed that effectiveness of protruded rectangular fin is better than uniform rectangular fin.
- ❖ Figure 08 shows the variation of Efficiency of both fins protruded rectangular fin and Uniform rectangular fin with change in Power supply (Voltage) in natural convection. I observed that efficiency of protruded rectangular fin is better than uniform rectangular fin.
- ❖ Figure 10 shows the variation of heat transfer of both fins protruded rectangular fin and Uniform rectangular fin with change in Power supply (Voltage) in natural convection. I observed that Heat transfer retain protruded rectangular fin is better than uniform rectangular fin.
- ❖ Figure 11 shows the variation of heat transfer of both fins protruded rectangular fin and Uniform rectangular fin with change in Power supply (Voltage) in forced convection. I observed that Heat transfer rate in protruded rectangular fin is better than uniform rectangular fin.

V. CONCLUSION

The objective of this project work was to find out a comparative experimental study and performance of uniform rectangular and protruded rectangular fin in both natural and forced convection analysis. Complete comparative study of uniform rectangular and protruded rectangular fin has been done successfully and following conclusions have been made: -

- ❖ Temperature drop in protruded rectangular fin is more than uniform rectangular fin by 18.12% in natural and 16.33% in forced convection analysis.
- ❖ Effectiveness of protruded rectangular fin is greater than uniform rectangular fin in natural

convection by 35.49% and in forced convection by 29.19%,

- ❖ Heat transfer coefficient, Nusselt number and efficiency of protruded rectangular fin is more than uniform rectangular fin in both natural and forced convection analysis.
- ❖ Material requirement for protruded Rectangular fin is less compare to Uniform Rectangular fin for same performance.

VI. FUTURE SCOPE

In this project work I have calculated the values of heat transfer rate, effectiveness, heat transfer coefficient, Nusselt number and efficiency of uniform rectangular and protruded rectangular fin in both natural and forced convection analysis. This project work can be further extended to carry out the work with other materials like iron, steel, copper, porous material and also alloy with various compositions of material. Different fins profiles are used and compare the different fins parameter for same length. The relative effectiveness and performance parameters for various practical applications may be compared.

REFERENCES

- [1] Arora.S.C. And Doumkundwar,S.(1995),Course in heat and mass transfer, Dhanpat rai & sons,pp-5.3-6.6,India.
- [2] Arslanturk C. Optimization of straight fins with a step change in thickness and variable thermal conductivity, ThermalScience Technology 2010, vol.30 (pg. 9-19)
- [3] Azarkish H, Farahat S, Sarvari SMH. Comparing the performance of the particle swarm optimization and the genetic algorithm on the geometry design of longitudinal fin, World Acad Sci Eng Technol , 2012, vol. 61 (pg. 836-839)
- [4] Aziz,A.andFang,T.(2010),Alternative solutions for longitudinal fins of rectangular, trapezoidal, and concave parabolic profiles, Energy Conversion and Management 51 2188–2194,USA.
- [5] Aziz A, Nguyen H. Two dimensional performance of convecting–radiating fins of different profile shapes, WaermeStoffuebertrag , 1993, vol. 28 (pg. 481-7)
- [6] Balaram Kundu, Kwan-Soo Lee, Antonio Campo An ease of analysis for optimum design of an annular step fin.Int. J. Heat Mass Transf., 85 (2015), pp. 221-227.
- [7] Balpande,A.andBute,j.andAndsable,V.(2015),Theoretical investigation of triangular fin-A Review,International journal for engineering application and technology,ISSN:2321-8134,Manthan-15, India.
- [8] BaskayaSenol, SivriogluMecit, and Ozek Murat, 2000, Parametric study of natural convection heat transfer from horizontal rectangular fin arrays, Int. J. Thermal Science, 39, 797–805.
- [9] Bergman TL, Lavine AS, Incropera FP, et al., Fundamentals of Heat and Mass Transfer, 2011 7th edn John Wiley & Sons.
- [10] Bilirgen,H.andDunbar,S.(2013),Numerical modeling of finned heat exchangers. Applied Thermal Engineering ; 61:278-288,USA.

- [11] CihatArslanturk., (2011), "Performance analysis and optimization of radiating fins with a step change in thickness and variable thermal conductivity by homotopy perturbation method".
- [12] Daund, V. S., A. A. Walunj, and D. D. Palande. "Review of natural convective heat transfer from rectangular vertical plate fins." *International Journal of Advanced Technology in Engineering and Science* 2, no. 7 (2014): 294-304.
- [13] Daund,V.S. and Palande,D.D.(2014),Effect of Low Aspect Ratio on Convective Heat Transfer from Rectangular Fin Array in Natural Convection *International journal engineering sciences & research technology*, ISSN: 2277-9655,pp-181,India.
- [14] Domkundwar&Domkundwar, (2011). *Heat and Mass Transfer Data Book:DhanpatRai and Co.*, (pp. 3.2, 3.5,3.13)
- [15] Fabbri, Giampietro. "A genetic algorithm for fin profile optimization." *International Journal of Heat and Mass Transfer*40, no. 9 (1997): 2165-2172.
- [16] Guo,S.andZhang,J.andLi,G.andZhou,F.(2013),Three-dimensional transient heat conduction analysis by Laplace transformation and multiple reciprocity boundaries face method. *Engineering Analysis with Boundary Elements*; 37:15-22, China.
- [17] Hollands, K. G. T., and Stedman, B. A., (1992), "Optimization of an Absorber Plate Fin Having a Step Change in Local Thickness," *Solar Energy*, 49, page 43–45.
- [18] Hossain, S., Raiyan, M. F., Sayeed, S., & Ahamed, J. U. (2015). Analysis of Thermal Characteristics of Flared and Rectangular Fin Profiles by Using Finite Element Method. *IOSR Journal of Mechanical and Civil Engineering*, 12(5), 58-67.
- [19] Incropera, F. P., and Dewit, D. P., 2007, *Fundamentals of Heat and MassTransfer*, 6th ed., Wiley, New York.
- [20] Kern, D. Q., and A. D. Kraus. "Extended Surface Heat Transfer, McGraw-Hill, New York, 1972."
- [21] Kobus CJ, Cavanaugh RB. A theoretical investigation into the optimal longitudinal profile of a horizontal pin fin of least material under the influence of pure forced and pure natural convection with a diameter-variable convective heat transfer coefficient, *J Heat Transf*, 2006, vol. 128 (pg. 843-6).
- [22] Kumar,D.S.(2011),*Heat and Mass Transfer,S.K.Kataria& Sons,pp-233-271,India.*
- [23] Kundu, B., and P. K. Das. "Performance analysis and optimization of annular fin with a step change in thickness." *Journal of heat transfer* 123, no. 3 (2001): 601-604.
- [24] Kushwaha,A. and Kirar,R.(2013),*Comparative Study of Rectangular, Trapezoidal and Parabolic Shaped Finned*