

Review on Solar Powered Cold Storage

Shrikant D. Kathwate, PhD Research scholar, Department of Mechanical Engineering, G H Raisoni college of Engineering & Management, Pune, India, shrikant.kathwate@raisoni.net

Nitin U. Korde, Professor, Department of Mechanical Engineering, G H Raisoni Institute of Engineering & Technology, Pune, India. nitin.korde@raisoni.net

Abstract - The major issues for bad economical condition of farmers in India is that shortages of cold chain arrangement which is responsible for post harvest losses of fruits and vegetables. There is a need to develop more number of cold storages systems. As installation cost and running cost of cold storages is very high it is not convenient for farmers to build up system by their own. Running cost can be reduced by developing solar powered cold storage systems, Instead of using grid power. This paper discussed different solar systems used for power generation for cold storages.

Keywords: Cold storage, Power generation, solar PV panels, Solar Collectors, VARS, VCRS

I. INTRODUCTION

In developed countries and developing countries the trend is to use more and more renewable energy sources for power generation. Solar energy is most useful renewable energy source to produce power for various applications. Post harvest losses of fruits & vegetables get direct impact on economical conditions of farmers, If market cost of products is not suitable then there is a need to store products and sell the products when market prize of products get raised. To store fruits & vegetables cold chain arrangement is needed to maintain quality of products for longer duration. Every product needed certain temperature and humidity ranges for storing. Some products such as oranges, Grapes, chilli, Brinjal, Melon etc. needed pre cooling process. The cold storage running on grid power have very high installation cost & Running cost [1]. It is not possible to reduce installation cost but running cost can be reduced by using renewable energy as alternating power source instead of grid energy. So various researchers used solar energy as power source to run both VCRS & VARS based cold storage systems. The use of solar energy for power generation based on two methods.

II. SOLAR PHOTOVOLTAIC PANELS

Different types of solar PV panels was used to convert solar energy in to power which was used to run cold store system instead of grid energy. Some researchers used battery backup systems. Mishra et al. [2] designed & developed 10 tonnage solar powered 2 tonnage split AC cold storage system. Total 22 nos. of Polycrystalline solar panels of 325 W capacity each was used. For night time, rainy days power supply battery bank arrangement was used as shown in block diagram fig.1

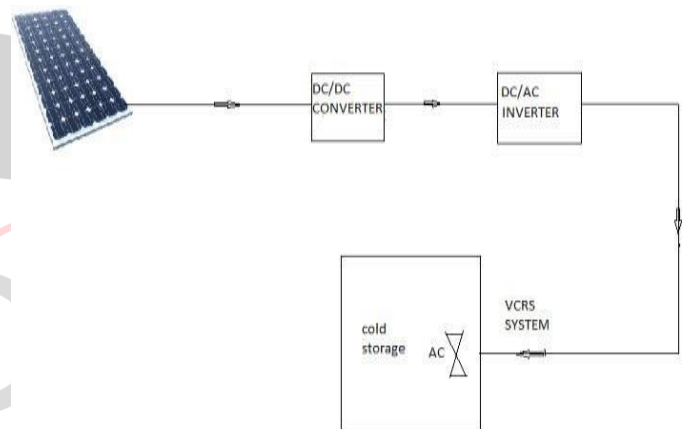

Fig.1 Solar hybrid cold storage system using PV panel for power generation

IOT based sensors was provided to control temperature of 6°C to 7°C and relative humidity of 94% to 95%. The purpose of system was to reduce running cost so that group of farmers taking same crops can install the system at their own farm and post harvest losses was reduced resulting increased in yearly income of farmers. Inside and outside temperatures and relative humidity noted down for 7 days.

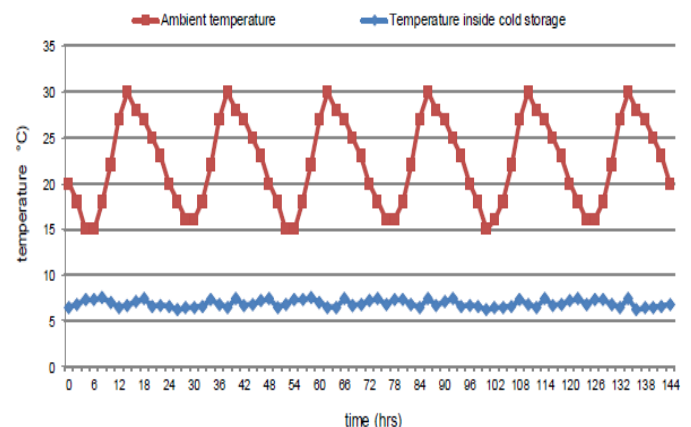

Fig. 2 Temperature Vs Time for outside temperature & inside temp. [1]

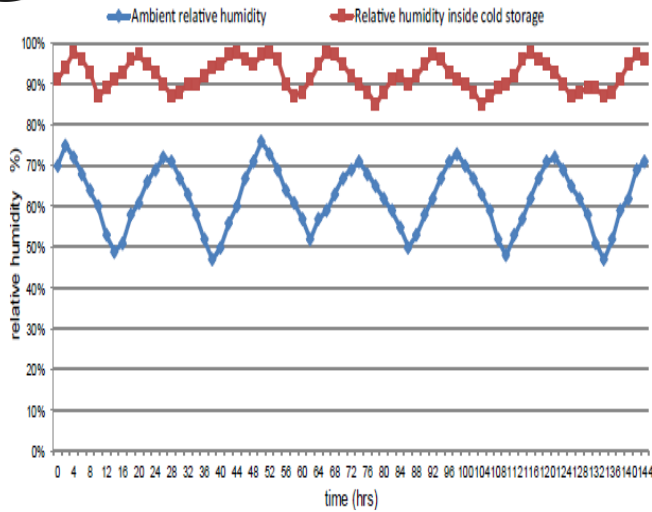

Fig 3. Relative humidity Vs Time for outside & inside condition [1]

It was found that designed system was better in terms of energy saving, cost saving and simplicity as compared to conventional cold storage system. The total cost of system was estimated to be \$ 15710 in India. When compared with conventional refrigeration cold storage system per year saving of farmer was \$ 7449. Anish et al. [3] designed a solar hybrid cold storage system integrated with 16 Kgs of PCM, 43.6 V of solar PV panels was used. During daytime when sunlight available solar PV panels converts solar energy in to electrical energy, which was used to operate VCR system and to maintained temperature of 4^oC to 7^oC inside cold chamber also PCM material save ROM05-P was filled in rectangular aluminium tubes and placed inside walls. So during cooling process PCM absorbed latent heat and get charged, during night PCM released coolness and maintained temperature inside chamber. Experimentation was done with and without PCM and found that by using PCM 16 % Energy consumption was reduced. As shown in fig.3 experiment was conducted for cold storage with combination of solar system for power generation and PCM and found that system was able to maintain required set temperature inside chamber by 35% more time than conventional refrigeration system.

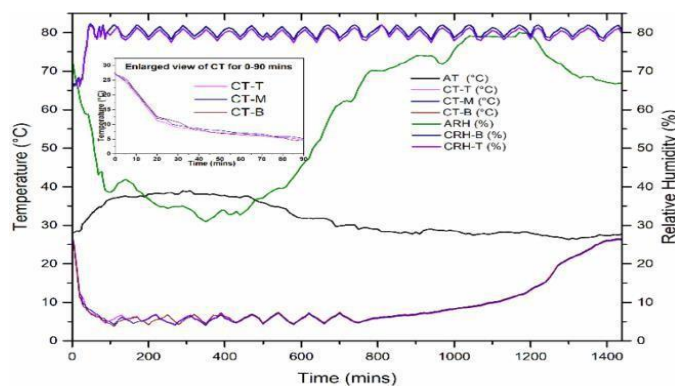

Fig.4 Temperature and Relative Humidity Vs Time [3]

Ramen et al. [4] developed solar driven cold storage compared single effect and double effect vapour absorption

system. System was equipped with both parabolic trough collector and PV module as source of energy. The generator was operated by using hot fluid supplied by collector and electrical energy to heater was supplied by PV solar module. In case of single effect VAR system single generator and heat exchanger was used while in case of double effect system two generators and heat exchangers were used to produce cooling effect. Double effect VAR system was better than single effect VAR system in terms of COP was 80 % higher, exergy energy was 16 % higher. Payback period for single effect VAR system was 3 years, 6 months while for double effect VAR system it was 4 years. Some researchers Surender et al. [5] developed solar hybrid cold storage system for applications like mobile transportation to maintain quality of products during transportation. Air conditioner in cooling chamber was run on vapor compression refrigeration system. Power was generated by Solar PV panel Electric circuit was used to maintain rotational speed of compressor for required predetermined temperature in cooling chamber. The average working time in a day for VCR system to run was consider as 12 Hrs and for 7 to 8 Hrs cooling was maintained inside chamber by PCM. It was found that the installation cost of system was higher but running cost was less as compared to conventional transportation refrigeration system. Bharj et al. [6] has investigated for same system with combination of DC inverter technology and solar PV panel the system was considered as economically good system used for multipurpose.

III. SOLAR COLLECTORS

In solar PV panels the electricity was generated using solar PV cells, but this systems required batteries to store energy which costs high. So researchers found that solar thermal systems which runs absorption refrigeration system are economically more suitable than Solar PV panels. Fig 4 represents the block diagram of basic hybrid solar collector VAR cold storage system.

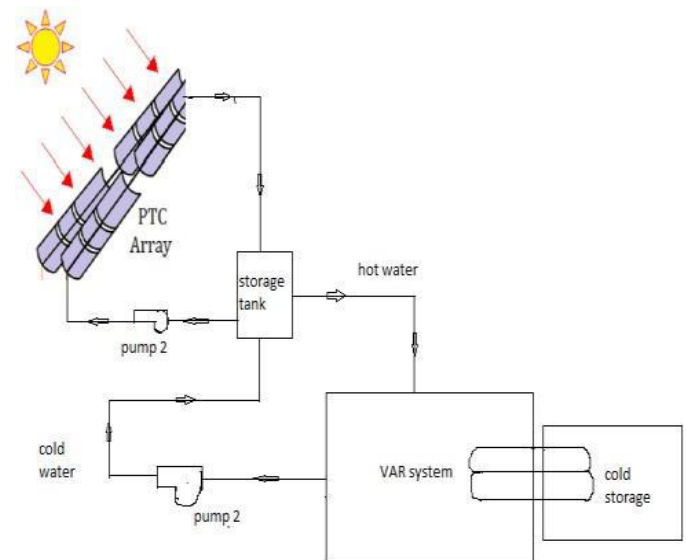

Fig.5 Hybrid solar collector VAR cold storage system

Sadi et al. [7] compared performance of flat plate collector (FPCS), Evacuated tube collector (ETCS) and Parabolic trough collector to design 5TR cold storage for potatoes. PV panel was installed to provide electricity required to run pump, fan etc. All the three collectors arranged in series to run absorption chiller which produces cooling effect in cold chamber. It was found that the cost of PTCs collectors was higher as compared to other two collectors also COP of system integrated with PTCs was less. The emission of CO₂ was reduced by 53% as compared to conventional absorption chiller using natural gas. Fig.4 shows COP obtained in terms of hours for each type of collector in most cases value of COP was 0.74.

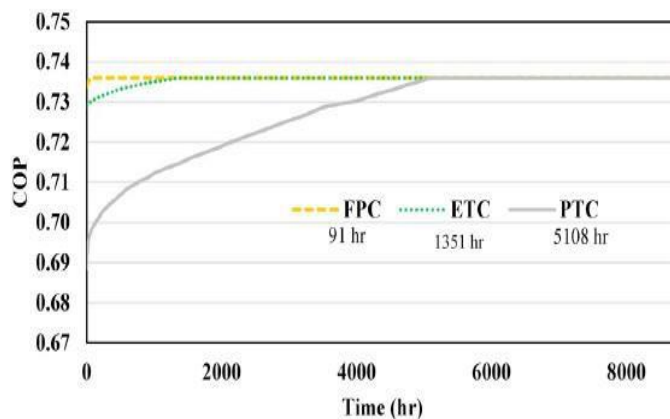

Fig.6 COP for EPC, ETC, PTC Vs Time (Hr) [7]

Bahram et al. [8] used solar dish collector of each area 12.56 m² to run absorption chiller and produce refrigeration temperature of -23.51°C the refrigeration cycle used was ammonia water absorption also system was integrated with PCM which stores cooling energy produced by absorption chiller during day and released that cool energy during night. The system was developed in Bandar Abbas, south Iran, solar dish received 1649 KW heat and produced 373.5 KW of refrigeration effect for refrigerator. After conduction exergy analysis it was found that total exergy efficiency was 45.14%. Tushar Sharma [9] planned and built up a sun oriented controlled cold stockpiling framework to store 200 kgs of potatoes. The framework comprises of sun powered board, blower, condenser, choking gadget, Evaporator and Ice nuclear power stockpiling (ITES) framework. During daytime sunlight based fueled energy was utilized to work cold stockpiling and during evening time as there is no sun oriented force ITES framework was worked where inert warmth was put away during daytime as frozen ice. The outcomes by utilizing ITES framework was energy effective. Lin et al. [10] created sun powered air conditioning coordinated with microencapsulated phase change material to save energy. Evacuated tubes was used as thermal power source and cooling impact was delivered during daytime, likewise energy was put away in PCM. Without daylight or stormy days energy put away by PCM was utilized to create cooling impact. At the point when temperature of PCM expanded above 10°C, ordinary

cooling measure was begun and cooling impact was delivered by compressor same time PCM was charged. When contrasted and typical air conditioning framework created framework saved 30.5% energy. Framework was more steady and ready to keep up temperature of 18 °C to 22°C. Basu et al. [11] Planned and investigated Solar-Thermal Photovoltaic fueled framework to store potatoes at 10°C. The framework was coordinated with water lithium bromide ingestion framework. It was presumed that 165 modules of pm-150 in corresponding with 50 numbers of FPC's force cold stockpiling framework effectively on yearly premise. Coordinated force framework was given net energy yearly excess of 36MW hr over schedule year. Lin et al. [12] investigated phase change material cold stockpiling framework applied to sunlight based controlled cooling framework. Surveyed the Air molding framework utilizing sun based energy for power age and PCM Material as energy stockpiling. Creator reviewed various sorts of sun based fueled cooling framework contrasted framework progress and straightforward frameworks.

IV. CONCLUSION

To reduce running cost of cold storage researchers used different solar collectors as thermal energy source to operate VAR system and produce refrigeration effect. Also some researchers used PV panels to generate electrical energy, battery bank was provided to store energy either direct energy produced during availability of sun was used to run system or in Night time or rainy days energy stored in battery bank was used. Further researchers increased efficiency of system by integrating system with different PCM. Which absorbs cooling energy during system working hours and released cooling energy during night time.

REFERENCES

- [1] Priyanka Sakare “ Design of cold storage for thousand tones potatoes “ International journal of agriculture and food technology, pg 171-178, 2014.
- [2] R. Mishra, S.K Chaulya, G.M Prasad, S.K Mandal, G Banerjee, “Design of a low cost, smart and stand-alone PV cold storage system using a domestic split air conditioner” Journal of stored products research 89,Elsevier, 17 Oct 2020.
- [3] P. Sarafoji, V. Mariappan, R. Anish, K. Karthikeyan, Jayabharata Reddy, “Performance study of solar photovoltaic cold storage system using phase change materials,”Materials today - Proceedings, Elsevier, pg. 2214-7853, July 2020.
- [4] Ramen Kanti De, Aritra Ganguly, “ Performance comparison of solar -driven single and double effect LiBr – water vapour absorption system based cold storage”Thermal science and Engineering progress, Elsevier, pg. 2451-9049, 23 Jan 2020

- [5] Surender Kumar, Dr. R.S Bharj “Design for solar hybrid mobile multipurpose cold storage system,”IJTRS, ISSN No. 2454-2054, Vol.1 Issue 9, Dec 2016.
- [6] Dr. R.S Bharj, Surender Kumar, “Energy efficient hybrid solar system for cold storage in remote areas,”IJERT, ISSN No. 2278-0181,Vo.4 Issue 12,Dec 2015.
- [7] Meisam Sadi, Ahmad Arabkoohsar, “Technoeconomic analysis of off- grid solar- driven cold storage systems for preventing the waste of agriculture products in hot and humid climates,”Journal of cleaner production, Elsevier, pg no. 0959-6526, 11 Sept 2020.
- [8] Bahram Ghorbani, Mehdi Mehrpooya,“ Concentrated solar energy system and cold thermal energy storage (process development and energy analysis),” Sustainable energy technologies and assessments 37, Elsevier, pg no. 2213-1388, 2020.
- [9] Tushar Sharma “ Design & Development of solar powered cold storage system” Hof. University of applied sciences, July- 2018.
- [10] Lin Zheng, Wei Zhang*, Lingzhi Xie, Wei Wang, Hao Tian and Mo Chen “Experimental study on the thermalperformance of solar air conditioning – system with MEPCM cooling storage”International journal of low carbon technologies 14 pg 83-88, 2019.
- [11] Dipankar N. Basu, A Ganguly “ Solar thermal Photovoltaic – Powered potato cold storage conceptual design and performance analyses. Applied energy ,165 ,308-317, 2016.
- [12] Lin Zheng, Wei Zhang and Fei Liang “A review about phase change material cold storage system applied to solar power air conditioning system”, SAGE, Vol.9(6) 1 – 20, 2017.