

Alcohol Detection and Engine Locking System Using Arduino Uno with GPS Tracker

Dr. V. Kumara Swamy¹, M. Srikanth², Y. Veerabhadra³, S. Navaneeth⁴

¹Associate Dean (Academics), ^{2,3,4}UG Student, Dept. of ECE, Sreenidhi Institute of Science and Technology, Telangana, India. ¹ksvarkuti@gmail.com, ²medaboinasrikanth1@gmail.com, ³yelagandala.veerabhadra@gmail.com, ⁴siddhollanavaneeth41@gmail.com

Abstract The Alcohol Sensor and Arduino-UNO as the controlling unit are used in this project to build and construct an Alcohol Detection with Engine Locking for vehicles. The system will continually monitor the amount of alcohol concentration using an alcohol detection sensor, and if the alcohol concentration exceeds the threshold level, the vehicle's engine will be turned off. Using the SIM800A and NEO6M GPS modules, this model will also send a message to the registered cellphone number with the vehicle's position.

Key Words: *Arduino UNO, Alcohol sensor, Buzzer, LED, SIM800A, MQ-6 Sensor, NEO6M.*

I. INTRODUCTION

The concept described in this project report is aimed to regret the drunken driver by not allowing driving the vehicle. When this system is installed in a vehicle over the dashboard and detects the drunken driver through the alcohol sensor, the simulated vehicle presented here with a DC motor, which will be stopped automatically, treated as engine shutdown. Since the availability of the exact sensor is not possible and since it is a prototype module, the basic concept is proven with the universal sensor which can detect all sorts of toxic gases, petroleum products, smoke, etc., in addition, to the alcoholic vapor. The sensor used here is named MQ6. Since it can detect all sorts of toxic vapor and is available easily everywhere, it is said to be the universal sensor. This sensor is used here to detect alcoholic vapors. Presently, this kind of sensor can be used for goods transport vehicles, because these vehicles will not carry passengers. At the point when this sensor is utilized in vehicles, it is hard to recognize the tanked individual in light of the tipsy travelers. Henceforth it is prescribed to involve this innovation in trucks just because the truck contains a separate lodge for the driver and his associate. If a proper sensor is used, it can be installed in cars also. One benefit of utilizing this sensor is that it cannot distinguish minimal far fumes, since it isn't the case delicate. It is supposed to be an advantage since it shouldn't identify other tipsy people the individuals who are minimum away from the driving wheel. This shows that the sensor should be introduced over the dashboard and that direction should be extremely close toward the driving wheel. Assuming that this sort of course of action is made in the lodge, the framework can identify just a tipsy driver. As portrayed over, the sensor isn't delicate, during a demo, the sensor should be presented to the liquor fume.

For this purpose, pour little alcohol (brandy or whiskey) into a small cup and place the sensor a little above the cup with a gap of 2 to 3cms approximately. Contingent upon the liquor fume focus in the air, the conductivity of the sensor will be changed and in light of this conductivity, outplaced in the structure of voltage levels will be varied automatically. These varieties are observed through the operation amp and a high sign will be created at whatever point the sensor recognizes liquor fumes in the air.

The result of the MQ-6 sensor is utilized to set off the Op-amp, this operation amp arranged as a voltage comparator can produce a rationale high sign when sensor yield is greater than the reference voltage. Based on this signal, the microcontroller used as the processing unit is programmed to energize the alarm and flashing type red light simultaneously. In addition to the simulated ignition in the form of push-button and though it is activated, the motor will not be energized, creating the situation of engine shut-down, and the location of the vehicle is sent to the registered mobile number using the GSM and GPS modules.

The innovation introduced here is exceptionally basic, it tends to be utilized as a demo module, yet when it will be utilized for genuine applications, every one of the vehicles should be furnished with genuine sensors which can recognize even a little grouping of liquor fumes present in the air.

II. LITERATURE SURVEY

These days, many accidents are happening due to the liquor consumption of the person who is driving the vehicle. Alcohol Detectors installed inside the vehicle can provide safety to the people seating inside the car. An alcohol breath analyzer should be fitted/installed inside the vehicle. Another age of innovation is coming to fruition around frameworks that keep vehicles from working assuming the driver is tanked.

Scientists say the innovation is promising to the point that they contrast it with the coming of the safety belt concerning its true capacity. This is the best option to prevent drunken driving.

Analysts are creating two states of the art draws near:

- **Breath.** A framework estimates blood liquor levels from a driver's breath. The levels would be identified from sensors mounted before the driver. Yet, the driver shouldn't know they are being observed.
- **Touch:** This strategy would evaluate for liquor when the driver contacts the beginning button or one more assigned surface in the vehicle. Liquor levels would be estimated under the skin's surface on a couch cushion with an infrared light scanner.

A. Breath analyzers – an overview:

A breathalyzer is a device that measures the amount of alcohol in your blood after you do a breath test. Breath analyzers do not directly assess blood liquor content or focus, necessitating the use of a blood test. In the end, they estimate how much liquor is in one's breath to determine BAC in a roundabout method.

Alignment is the process of comparing and altering a breath analyzer's test findings with a recognized liquor standard to examine and change its interior settings. Policing analyzers must be fastidiously kept up with and yet again adjusted often to guarantee precision. There are 2 strategies for aligning an accurate energy component breath analyzer, the Wet Bath and the Dry Gas strategy. Every strategy needs particular gear and plant-prepared specialists. Not a technique can be directed by undeveloped clients or without legitimate gear.

B. Mouth alcohol:

Quite possibly the most widely recognized reason for falsely detecting alcohol is the presence of alcohol in the mouth. In examining a breath of subject test, the breath analyzer inside the system is making the wrong assumption that the alcohol in the breath test came from air breathed out from the lungs. Be that as it may, alcohol might have come from the mouth, stomach, or throat for different reasons. To avoid mistakes/wrong assumptions due to the mouth-liquor defilement, affirmed breath-test administrators are prepared to notice a guinea pig cautiously for something like 15 to 20 minutes before starting the test. The problem with mouth wine being examined by a breath analyzer is that it was not digested through the stomach and digestive systems and instead traveled to the lungs via the bloodstream. After all, the machine's PC is applying the segment proportion incorrectly and repeating the result. Thus, an extremely minuscule measure of liquor from the mouth, throat, or stomach can essentially affect the breath-liquor perusing.

III. PROPOSED METHODOLOGY

The block diagram shown in the next chapter consists of important devices like

MQ6 alcohol sensor, Arduino-Uno, GSM module, GPS module, op-amp, DC motor, Relay, buzzer

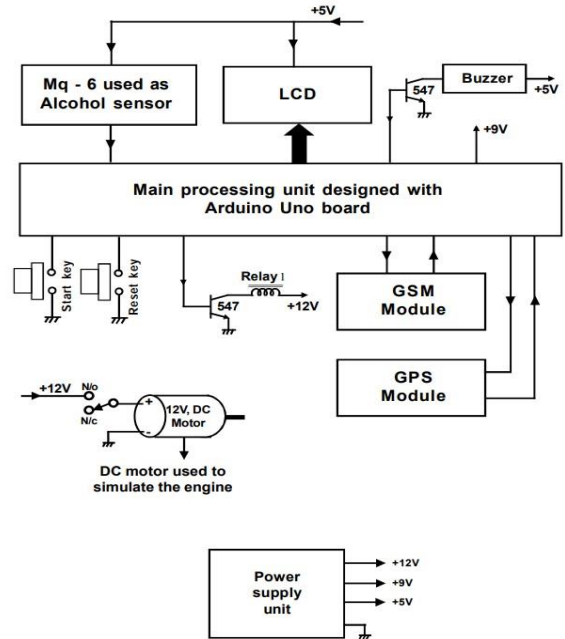

Fig-1: Block Diagram

A. Hardware Implementation

Arduino is connected with input and output devices as shown in Fig-1. The analog output of the MQ-6 alcohol sensor is connected to the A0 analog pin of the Arduino-Uno. Two switches 'START' and 'RESET' are connected to the A1 and A2 pins of the Arduino-Uno. The remaining modules like LCD, GSM module, GPS module, Buzzer, and DC Motor are connected to the 14 Digital input-output pins of the Arduino. The Power to the circuit is supplied using the regulated power supply which consists of a Step-Down Transformer that is used to decrease the 240V AC, a Centre-Tapped full-wave rectifier, and a filter and regulator that are used to convert the AC voltage to DC voltage.

B. Working

Arduino-Uno is used as the central processor for the working of the circuit. After the circuit is supplied with the power, the 'START' switch is used to turn ON the DC motor which is assumed as Engine 'START'. The DC motor will be ON until an Alcohol is detected by the MQ6 sensor. If the Alcohol percentage in vapor increases a certain threshold value the Arduino-Uno which is preprogrammed to detect the increase in alcohol level switches OFF the DC motor and turns ON the Buzzer to beep. At the same time, the Alcohol percentage and coordinates of the vehicle are displayed on the LCD. The GSM module is used to send the SMS to the registered mobile number with the location of the vehicle. Arduino-Uno uses SoftwareSerial() for the communication between Arduino and GSM module. The Rx and Tx of GSM are connected to any

two digital I/O pins which are programmed for serial communication. The Tx pin of the GPS module is connected to the Rx pin (Digital pin 0) of the Arduino. The location of the vehicle is transmitted using UART transmission. After detection of the Alcohol, 'RESET' is used to switch off the Buzzer and start the DC motor again.

C. Arduino-Uno

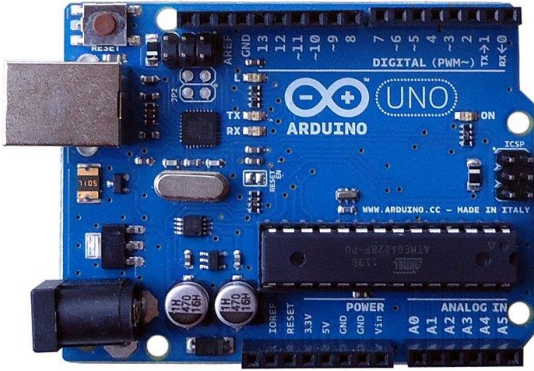

Fig-2: Arduino-Uno

The above figure is Arduino-Uno which is an open-source hardware and programming organization, project, and customer community that develops sophisticated gadgets and intelligent goods using single-board microcontrollers and microcontroller packs that can detect and regulate with precision and attentiveness. At a cheap cost, Arduino sheets may be purchased pre-assembled or as DIY (Do-It-Yourself) kits.

The Arduino Uno is a microcontroller board that uses the ATmega328 microprocessor. It has a 16 MHz oscillator, a Universal Serial Bus connection, a power jack, an in-circuit framework programming (ICSP) header, and a reset button. It has 20 computerized input/output pins (of which six can be used as PWM results and six can be used as simple information sources). Arduino is made up of a programmable circuit board (sometimes referred to as a microcontroller) and a piece of programming software, or IDE (Integrated Development Environment), that is used to create and transport PC code to the board. Arduino is an open-source contraptions platform that focuses on user-friendly hardware and programming. Arduino sheets can take inputs like light on a sensor, a finger on a button, or a Twitter post and turn them into outputs like a motor, an LED, or propagating anything on the internet.

D. MQ6

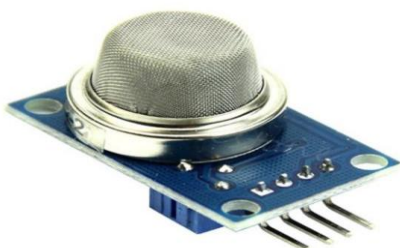

Fig-3: MQ6 sensor

The MQ6 sensor consists of 4 pins, they are VCC, ground, analog output, and digital output. The Analog output is connected to the Analog pin of Arduino-Uno through the Op-Amp comparator. Generally, the sensor used here is aimed to detect gas leakages, since it can detect all types of gasses and smokes it is used as a universal sensor and the same sensor is also used as an alcohol sensor. This sensor contains a semiconductor named tin dioxide (SnO_2); this sensor has low conductivity in clean air. If the air is not clean or it is polluted due to any reason, the conductivity level will be increased. Depending on the conductivity, its output will be varied proportionately. For example, though the air is clean some output in the form of voltage will be obtained from the sensor; this output is observed as 1V approximately. This means at a clean environment or fresh air, the sensor output will be 1V, during this condition if the sensor detects light smoke mixed with carbon dioxide it may generate 1.5V.

Similarly, if it detects concentrated cooking gas, the sensor may generate 2V, assume that the gas density or concentration is more, and the sensor may generate 2.5V. Likewise, the sensor output will be varied automatically depending on the type of gas or vapors found in the air. Here in our trail runs, we found that the sensor generates nearly 2V when it is kept over the alcohol dish. During our path runs, we utilized various kinds of alcohols like cognac, whisky, and so on. they are poured into a small container, and a sensor is placed above the container at a distance of one inch approximately. At this distance, the fixation will be more and thus it is seen that the sensor creates more than 2V.

If the distance is expanded, thickness will be diminished because the alcohol fume will be spread into the air, so contingent upon the distance sensor yield additionally changes proportionately. One important factor to be observed is, that the output is not similar when compared with another sensor, hence it is concluded that the output will differ from sensor to sensor. At long last, it is presumed that the result will be 2V roughly when it recognizes liquor fumes. Given this is worth reference voltage should be changed in like manner in the Op-amp circuit. Whenever the sensor output becomes high, i.e., more than the reference voltage, op-amp output will become high.

E. SIM800A GSM module



Fig-4: SIM800A Module

Fig-4 shows the SIM800A module that is used as GSM (Global System for Mobile Communication) module in this project. Send/receive SMS and voice calls using USART to communicate with a Microcontroller or PC. AT commands are used for configuration. The Rx and Tx pins are used for communication between Arduino.

The SIM800A Quad-Band GSM/GPRS Module with RS232 Interface is a fully working Quad-band GSM/GPRS module in LGA (Land lattice exhibit) configuration for client applications. SIM800A supports quad-band frequencies of 850, 900, 1800, and 1900 MHz, allowing it to connect voice, SMS, and data while consuming little power. It may fit into thin and modest handicraft requests thanks to its small dimensions of 100 x 53 x 15 mm. It allows all out-of-pocket investment money and a rapid opportunity to promote client applications by including an Embedded AT.

The SIM800A modem contains a SIM800A GSM chip and an RS232 interface, allowing for a simple connection to a PC or microcontroller through the USB to Serial adapter or the RS232 to TTL converter. When using the USB to RS232 connector to connect the SIM800A modem, use the Device Manager of the USB to Serial Adapter to determine the correct COM port. Then, using Putty or another terminal programming application, establish a connection to that COM port at a 9600 baud rate, which is the modem's default baud rate. You can start transmitting AT orders after a sequential relationship has been established through the PC or your microcontroller. When you send AT orders like "or," you should get a response from the SIM800A modem that says "Alright" or something similar, depending on the order you sent.

F. NEO6M GPS module



Fig-5: NEO6M Module

Fig-5 shows the NEO6M GPS (Global Positioning System) Module. It consists of 4 pins VCC, GND, Tx, and Rx. The Tx pin of the GPS module is connected to the Rx pin of the Arduino-Uno for TTL UART communication. GPS receivers function by calculating their distance from the satellites. These are pre-programmed to track the position of the GPS satellites at all times. The satellites transmit information about their position and the current time in the form of radio signals toward the Earth. These messages indicate the satellites and

inform the recipient of their location. The receiver then determines how much further away every satellite is by calculating the time it takes for the messages to arrive. It can determine the location on Earth once it knows how much further away at least 3 satellites are as well as that they're in space. This process is known as Trilateration.

It can track approximately 22 satellites across 50 bands and it has the greatest responsiveness in the field, -161 dB monitoring while consuming only 45mA of provided voltage. Unlike many other GPS processors, it can deliver up to 5 present geolocation every sec and has a zero steady-state accuracy of 2.5m. The Time-To-First-Fix (TTFF) of the u-Blox 6-position motor is less than one second. One of the processor's best features is Power Save Mode (PSM). It minimizes system power consumption by switching on and off segments of the receiver selectively. This reduces the component's energy usage to just 11mA, making it perfect for energy applications like GPS smartwatches. The NEO-6essential M's information ports

If you are meandering to explore the distance with a robot, this GPS Module is required for you. GPS drones are outfitted with a GPS module that permits them to know their area compared with an organization of circling satellites. Interfacing with signals from these satellites permits the robot to carry out roles, for example, position hold, independent flight, return to home, and waypoint route. This is a fully functional GPS module that uses the NEO 6M GPS. This gadget combines a larger implicit 25 x 25mm dynamic GPS radio wire with a UART TTL connector and employs the most cutting-edge innovation to supply the most precise positioning data.

A battery is also supplied to help you achieve a GPS lock faster. This is a new GPS module that works with the ardupilot mega v2 board. This GPS module provides the most accurate location data for use with your Ardupilot or any Multirotor control system. The GPS module has four pins: TX, RX, VCC, and GND, and it has a sequential TTL yield. You may get the u-focus programming to create the GPS and change the settings, among other things. It's excellent programming.

G. DC Motor

DC motor is linked to the Arduino through the relay, and the start button and reset button are used to control the motor. DC motor starts by pressing the start button and can be stopped by pressing the reset button.

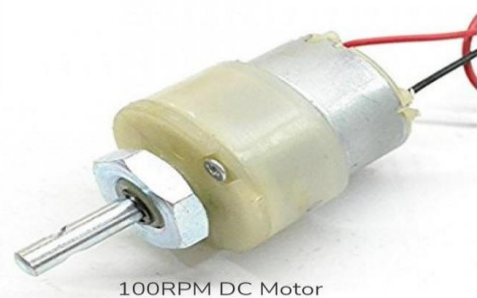

100RPM DC Motor

Fig-6: DC motor

Any type of electrical equipment that transfers electrical energy into mechanical power is referred to as a DC motor. The most prevalent varieties are those that rely on the energy generated by a magnetic field. Almost all DC motors contain an internal mechanism, whether electromechanical or electronic, that changes the direction of current flow in the motor component regularly. Many types generate rotating motion; the linear motor, on the other hand, generates power and motion in a straight line. Because they could be powered by existing light distribution systems, DC motors were the first commonly utilized kind. The speed of a DC vehicle may be varied over a large range by varying the supply voltage or adjusting the current power in its field windows. Tools, toys, and electrical appliances all employ small DC motors. The universal motor is a lightweight engine that can run on direct current and is used for portable power tools and electronics. Electric motors, elevators and hoists, and steering wheel drive all employ larger DC motors. In many applications, the introduction of electronic power has allowed the replacement of DC motors with AC motors practicable. The magnetic field produced by the current coil operating on it is aligned with the coil's center. Depending on the current and current flow, the direction and amount of the magnetic field created by the coil may be modified.

H. LCD Display

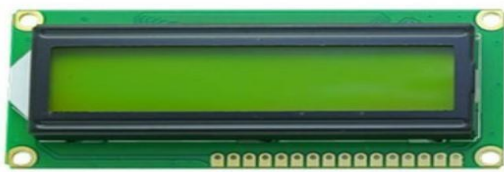

Fig-7 LCD

The display section began with an LCD screen, and the purpose of this screen is to reflect the driver's status, whether he or she is inebriated or not. The LCD panel used here has two lines, each of which displays 16 characters; however, depending on the 13 availability of LCD panels, three or four lines can be utilized to display a large amount of data. a greater number of times LCDs outperform LED displays because they can show alphabets, numerals, and special symbols, whereas LED (seven-segment display) can only show numbers. These LCD screens are useful for engaging with users and displaying information.

LCD monitors come in a variety of sizes and shapes. 2 x 16, which consists of two lines of 16 alphanumeric characters, is the most frequent. It also includes 3x16, 2x40, 3x40, and more specifications. LCD has mostly replaced LED in recent years due to its ability to display numbers, characters, and images. Another advantage is that more information may be presented as text messages or visuals due to the compactness and ease of programming for characters and pictures. In addition to the 8-bit data bus, LCD modules often have an 8-bit interface with a few more control lines. The control line

pins are attached to port '2', while the eight-bit data bus pin is connected to port '0'.The default data transfer between the LCD module and an external device is 8 bits, although only four of the eight data lines can be used to connect with the LCD module. Because the R/W line is connected to the ground, the CPU is unable to receive status information from the LCD module and can only write data to it.

Connection with Arduino-Uno:

The RS LCD PIN can be connected to any digital Arduino processor PIN, and the system should be set up to match the PINs. The floor is connected to the LCD P / P pin. For this project, the LCD module and Arduino module are connected in 4-bit mode. For LCD, there are four input lines ranging from DB4 to DB7. This is a really simple procedure that only requires a few wires and allows us to use a large amount of LCD module power.

Arduino pins 2-5 are coupled to digital input lines (DB4-DB7). A 1K potentiometer can be used to alter the display's brightness. A 100-ohm resistor controls the current flowing to the rear LED light. The PIN 2 LCD is powered by a +5V external power supply, while the Arduino board is powered by a 9V controller. Because the Arduino board has a built-in 5v internal controller, the input source for this board is around 9v. LCD screens have grown highly popular in recent years as a tool for evaluating parameter values, digital communications for sending or receiving text information, data acquisition systems, and other electronic devices.

I. LM324

The output of the alcohol sensor is fed to the LM324 as a variable source of voltage which varies according to the density of alcohol vapor present in the air. Here average density is considered and accordingly reference voltage value is adjusted at the second input of the op-amp.

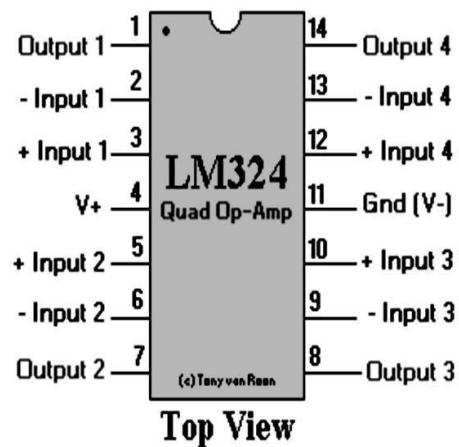

Fig-8: LM324 pin diagram

The LM324 series consists of 4 high-gain independent operational amplifiers which are compensated internally by frequency and specifically evolved to operate from a single source over a wide range of potential-difference. Potency

from separate power sources is also feasible, and the supply current consumption is low regardless of the value of the supply potential. Wide areas of application include transducer amplifiers; DC amplifier blocks, and op-amp circuits, which are now more easily created in single power supply systems. For example, this Op-Amp can be powered directly from a default +5V supply voltage, used in digital systems, and will easily provide the essential interconnection to electronics. The Op-Amp contains four high-gain, maverick op-amps with internal frequency compressed. All 4 IC741 operate over a wider range of potential difference voltage from a single supply. Also, use a distinct power supply. The device has less current consumption, nonetheless of the supply voltage. The low power consumption also makes the LM324 a better option for battery operation. These series are cheap-cost quad operational amplifiers with true differential inputs. They have several unique advantages over default op-amps in one source activities.

The op-amp used here is configured as a voltage comparator, in this configuration difference between the two inputs is monitored, if they are equal to each other then the output of the op-amp will become high. The sensor output is sent to the op-non-inverting amp's input, while the reference voltage is adjusted to about 1.6V using a fixed potential dividing network, commonly known as a voltage divider circuit, on the inverting input side. Here average value is considered as 2V, which means when the sensor detects the average density of alcohol vapor it may generate around 2V. In normal conditions, the sensor output will be less than 1.2V, if the air is polluted with alcohol vapors, then sensor output may rise to more than 2V. When this voltage is equal to the reference voltage or slightly more than the reference voltage, the output of the operational amplifier will become high and this high signal is fed to the microcontroller for further process.

J. Buzzer



Fig-9: Buzzer

A buzzer is an electronic part that produces sound to caution individuals close by. In this system, the buzzer is connected to the Arduino Uno, which gets input, whenever the alcohol is detected by the MQ6 sensor. Its frequency & tone is adjusted as per the requirements. It is very cheap & easy to use.

The Buzzer is classified into two types

Electromechanical:

Joseph Henry devised the electrical beep in 1831. They were often utilized in initial doorbells since they were taken out in the 1930s in favor of softer-toned melodic bells.

Piezoelectric:

Piezoelectric bells, often known as piezo buzzers, were created by Japanese manufacturers and used in a variety of items from the 1970s through the 1980s. This improvement was mostly the result of concerted partnerships by Japanese industrial enterprises. They formed the Barium Titanate Application Research Committee in 1951, which enabled the industries to be "competitively cooperative" and create various piezo advancements and breakthroughs.

IV. RESULT

If an alcoholic tries to drive a vehicle, the alcoholic sensor detects the presence of alcohol and shuts off the vehicle's motor, and emits a sound alarm, causing nearby people to become alert. With the help of the "LCD screen" installed in the vehicles, people groups become aware of the situation and take the appropriate action. Using the GSM and GPS modules, the vehicle's location is communicated to the registered mobile phone. All of the equipment is checked and linked as needed, resulting in the much-needed outcome seen below.

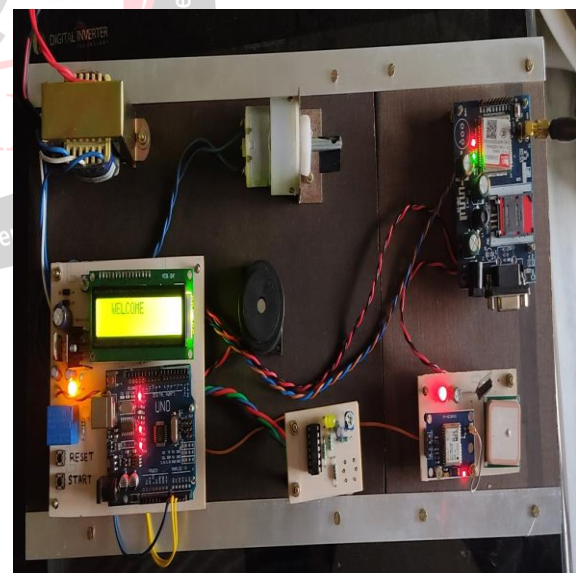

Fig-10: Prototype

The message which is sent to the mobile number is shown below. It contains the location of the vehicle.

6-14 12:51 PM

ALERT,ALCOHOL DETECTED
FOR VEHICLE NO.TS1234 AT
LOCATION: <https://www.google.co.in/maps/place/17.45836,78.68653>

ALERT,ALCOHOL DETECTED
FOR VEHICLE NO.TS1234 AT
LOCATION: <https://www.google.co.in/maps/place/17.45838,78.68652>

ALERT,ALCOHOL DETECTED
FOR VEHICLE NO.TS1234 AT
LOCATION: <https://www.google.co.in/maps/place/17.45842,78.68652>

Fig-11: Message to the mobile

V. APPLICATIONS AND ADVANTAGES

A. Advantages

Handy: The minimized and little estimated plan makes a unit as shown in the undertaking truly versatile. This implies that the unit can be hauled around easily and with solace. The strong state parts utilized in the task guarantee a decent life for the gadget and guarantee a long help life. Most organizations like the police and other regulation implementing offices depend on breath analyzers as they are helpful to utilize and extremely minimal simultaneously.

Easy and proficient to use: As should be visible in the show, the device is straightforward in development and simple to utilize. The outcomes acquired by the breath analyzer are reliable with the further tests led on blood tests of suspect people. The unit is not difficult to utilize and needs insignificant preparation and acquaintance. This helps keep the costs associated with the presentation of the gadget in different applications and activities.

Quick and exact: There is an insignificant time between the testing of a subject and the accessibility of results. This helps immensely in circumstances where countless subjects are to be tried as in rush hour gridlock policing. The outcomes are reliable and exact, making it reasonable for regulation implementing applications as the need might arise to stand the examination of different courts and allure frameworks set up.

B. Applications

- Most regulation authorizing specialists would have to screen the liquor level of drivers and coordinating the gadget to all the more likely to oversee individuals and vehicles are the need of great importance.
- Also, there are a ton of circumstances when individuals should be consoled of their well-being on the streets while hailing an outsider specialist cop like a taxi or a radio taxi. Subsequently, the requirement for well-being gadgets as shown in the

venture is felt by the vast majority profiting from such administrations.

VI. CONCLUSION

A low-cost and efficient solution is found for drunk driving accidents which are very common nowadays. Since we replaced Arduino-Mega with Uno in this project, it can be made cheaper as compared to previous projects and we have used the MQ6 sensor replacing MQ3 which is cheaper and more efficient than the MQ3 sensor. It provides an automatic system that senses the level of alcohol in the air and if it is more than the threshold level it shuts off the Vehicle's motor and makes the buzzer beep using hardware like Arduino-Uno, MQ6, DC motor, Relay, and Buzzer. This system also sends the location of the vehicle to the preregistered mobile number using the GSM (Global System for Mobile Communication) and GPS (Global Positioning System) modules. This enables the relatives and police officials to know the vehicle's location and further actions can be taken. This system decreases the number of accidents occurring due to drunk driving and thus increasing the safety features. Therefore, it is an efficient improvement in the automobile industry.

The future scope of this system is if alcohol is detected the vehicle stops in the middle of the road which results in traffic to avoid this problem we have to develop a system that makes the vehicle stop at the extreme left of the road.

REFERENCES

- [1] Beginning Arduino – Michael Mc Roberts
- [2] Getting started with Arduino – Massimo Banzi
- [3] A. ISuge, H.Takigawa, H.Osuga, H.Soma, K.Morisaki, Accident Vehicle Automatic Detection System By Image Processing Technology, ©IEEE 1994 Vehicle Navigation & ISC.
- [4] Pranjali Ingalepatil, Priyanka Barhate, Bhagyashri Nemade, and Vijay D. Chaudhari, "Alcohol Detection System in Vehicle Using Arduino," International Research Journal of Engineering and Technology (IRJET), e-ISSN: 2395-0056, p-ISSN: 2395-0072, Volume: 04 Issue: 06, June 2017.
- [5] S. Ramu, R. Dinesh, and, S. Naveen, "Vehicle Safety System with Alcohol Detector," International Journal for Scientific Research Development (JSRD), ISSN(online): 2321-0613, vol.5, Issue 12, 20
- [6] Swati Rajesh Parekar, Manoj M. Dongre, "An intelligent system for monitoring and controlling of street light using GSM technology", Information Processing (ICIP), 2015 International Conference on 19 Dec 2015.
- [7] Paul Baskett, Yi Shang, Michael V. Patterson, Timothy Trull, Towards A System for Body-Area Sensing and Detection of Alcohol Craving and Mood Dvsregulation, © 2013 IEEE
- [8] Landu Jiang, Xi Chen, Wenbo He, "SafeCam: Analyzing intersection related driver behaviors using multi-sensor smartphones", Pervasive Computing and Communications (PerCom), 2016 IEEE International Conference, 14-19 March 2016.
- [9] L. A. Navarro, M. A. Diño, E. Josen, R. Anacan, and R. D. Cruz, "Design of Alcohol Detection System for Car Users thru Iris Recognition Pattern Using Wavelet Transform," 2016 7th International Conference on Intelligent Systems, Modelling and Simulation (ISMS), Bangkok, 2016, pp. 15-19.